

TIME ZONES

24 hours = 360 degrees³

1 hour = _____ degrees

1 degree = _____ minutes

1 TIME ZONE = _____ DEGREES OF LONGITUDE

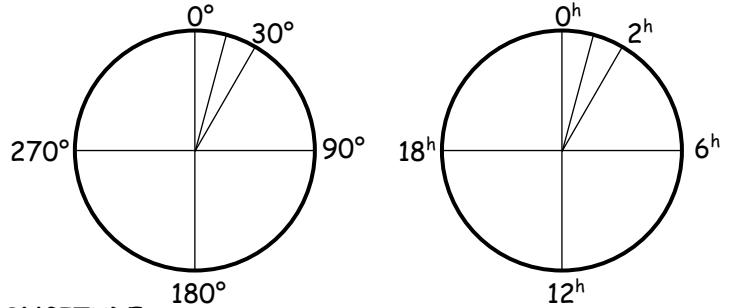

Starting at the Prime Meridian list the longitudes of the centers of western time zones:⁶

Name	Center Longitude
W. European	0° W
W. African	
Azores	
Brazilian	45° W
Atlantic	
Eastern	

Name	Center Longitude
Central	
Mountain	
Pacific	
Yukon	135° W
Alaska-Hawaiian	
Nome	165° W

The times of astronomical events are often given in **COORDINATED UNIVERSAL TIME (UT OR UTC)¹**, which is the time on the prime meridian (Greenwich, or Western European Time). The official time-keeper of the United States is the Time Service Department at the US Naval Observatory (www.cnmc.usff.navy.mil/usno/). Find the EST or EDT of the following events in the Spring of 2024 using the conversions:⁹

EST = UT - 5^h *Note that some of the dates may change if an event occurs between midnight UT and Eastern time*
 EDT = UT - 4^h

EST to EDT on March 8!

EVENT	UT		LOCAL TIME (EDT OR EST)	
	Date	Time (24 hr)	Date	Time (h:m AM/PM)
Full (Snow) Moon	February 1	22:09		
New Moon	March 19	1:23		
Vernal Equinox	March 20	14:46		
June Solstice	June 21	8:24	June 21	4:24 pm EDT

¹ Replaced Greenwich Mean Time (GMT) as the World standard for time in 1986. Also known as "Zulu Time," it is based on atomic measurements rather than the Earth's rotation. Greenwich Mean Time (GMT) is still the standard time zone for the Prime Meridian (Zero Longitude). Also, UTC is not the official time in any actual time zone. (www.timeanddate.com/time/gmt-utc-time.html)

Clock and Solar Noon

The **clock time** is the local clock time. Due to the finite width of the time zones, it does not always fit the solar meaning of time.

SOLAR NOON = SUN ON OBSERVER'S MERIDIAN (TRANSIT)

On the time zone center longitude, clock noon corresponds (roughly) to solar noon. For each degree of longitude of difference between your location and the center meridian, there will be four minutes of difference between your solar noon and civil noon.

EAST OF TZ CENTER: SOLAR NOON before civil noon.
WEST OF TZ CENTER: SOLAR NOON after civil noon.

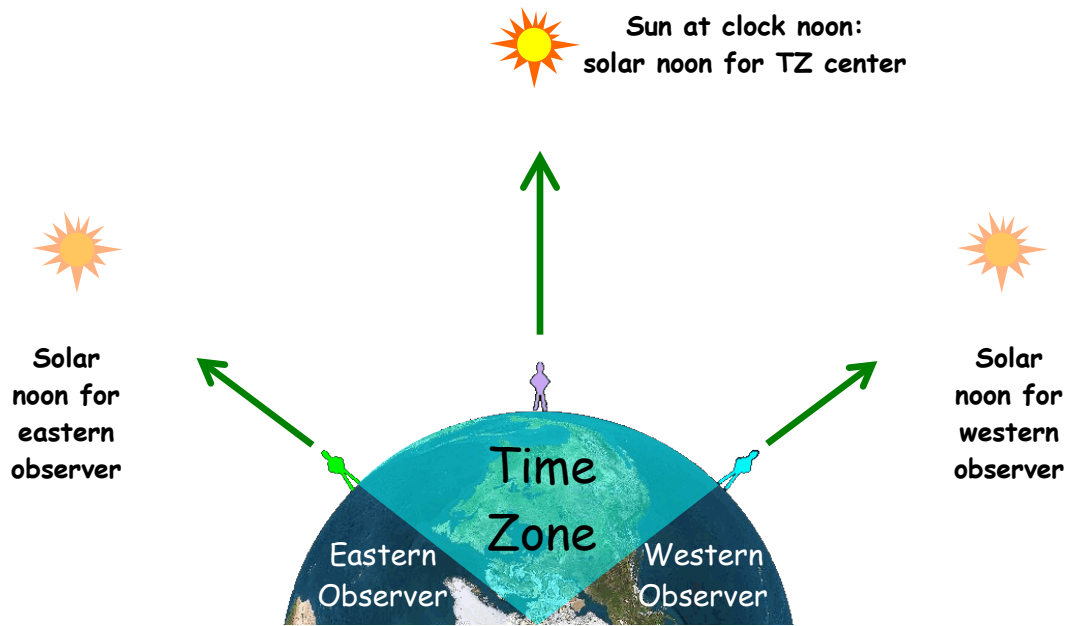

Thus solar noon occurs early in the eastern part of the time zone and late in the western part of the time zone. Complete the following table by calculating the difference between the city's longitude and that of the time zone center and using **1 hour = 15°, 4 min = 1°, and 1 min = 15'**.²⁰

City	Longitude				Solar Noon	
	City	Time Zone Center	Difference Deg. & min.	E or W	Early or Late	Clock Time
Gallup, New Mexico	108 45° W	105° W				
Portland, ME	70°15' W	75° W				
Thunder Bay, Ontario	89°15' W	75° W				
Lhasa, Tibet (CCT: UTC + 8)	91° E	120° E				

→ Longitude is measured **west to east** in the eastern hemisphere! **Use a globe!**